

Liftboy dimensions sheet

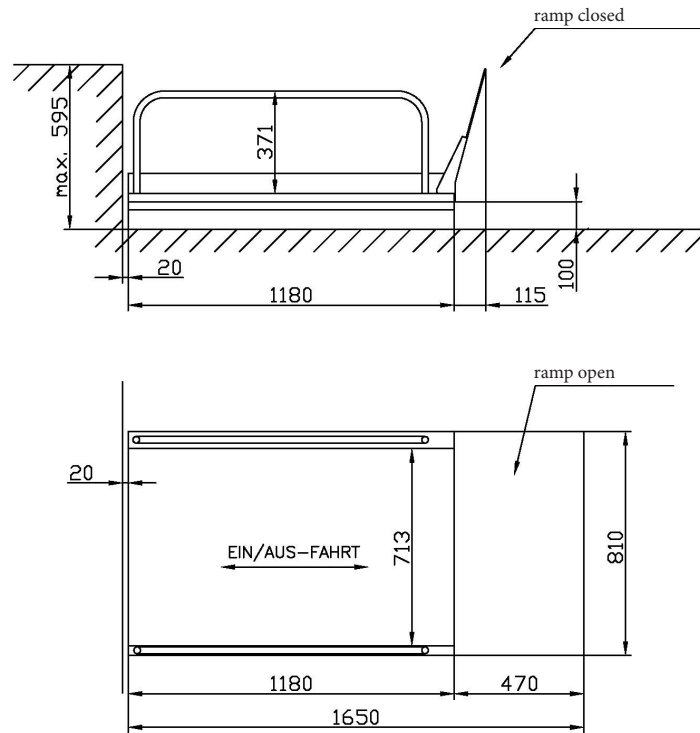

Liftboy type 1



loading capacity	180kg
lifting height	max. 595 mm
speed	10 mm/s
motor	24V / 0,2 kW
standard color	RAL 7035

Liftboy type 2

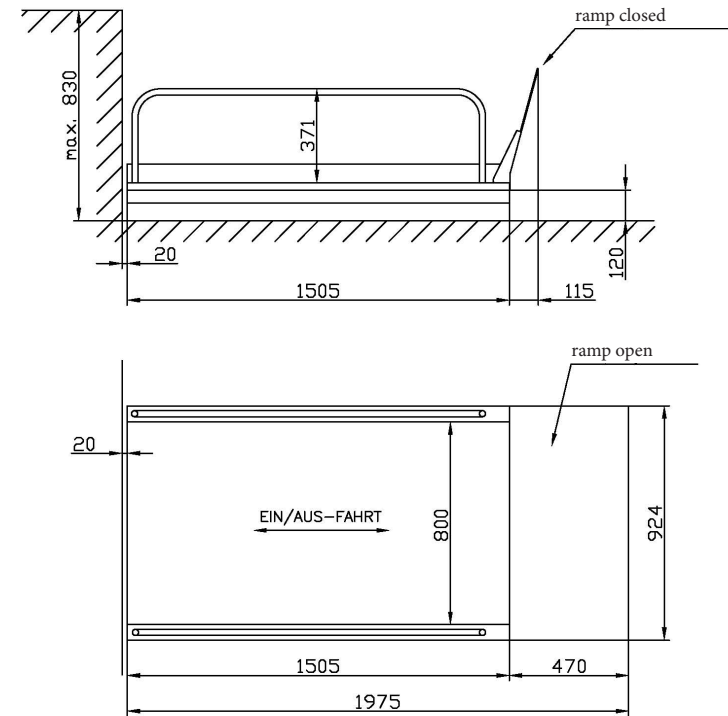

loading capacity	300kg
lifting height	max. 830 mm
speed	10 mm/s
motor	24V / 0,2 kW
standard color	RAL 7035

Liftboy with 750mm ramp

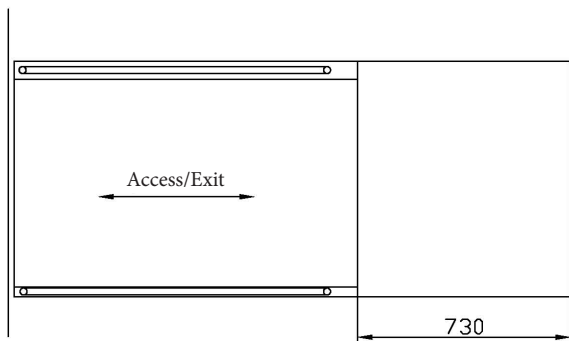
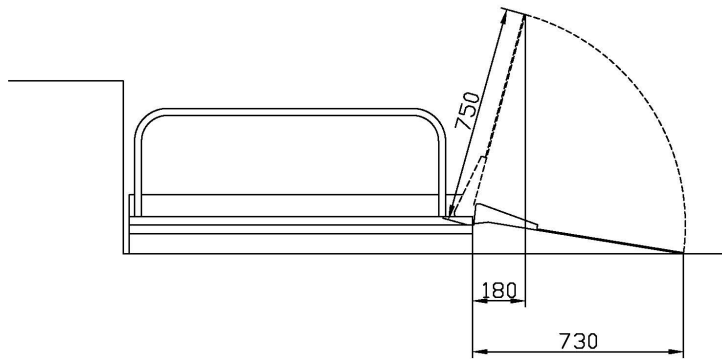
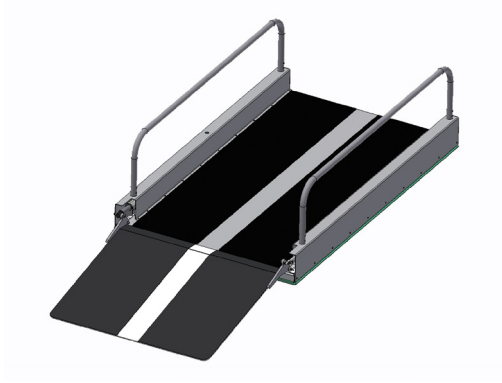

Pillar for control panel

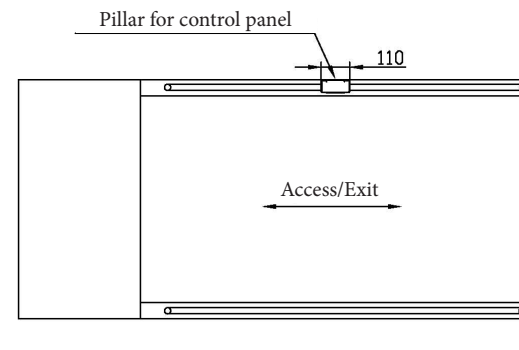
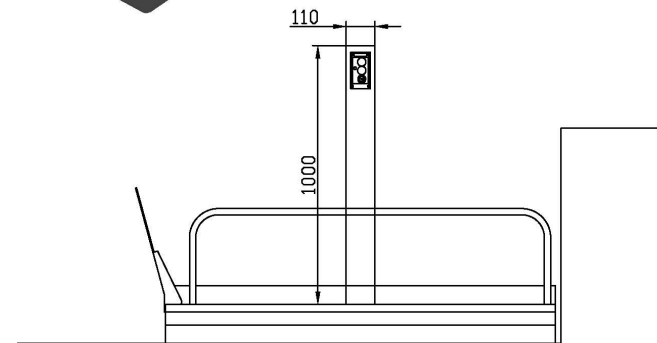
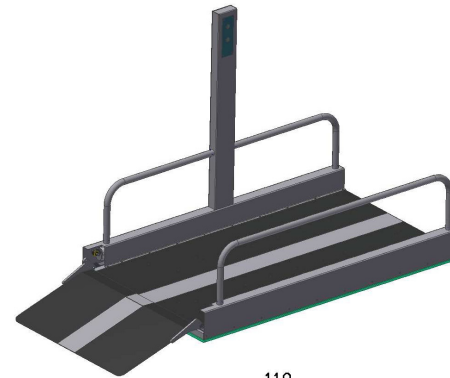

Side access on lower landing (showing type 2)

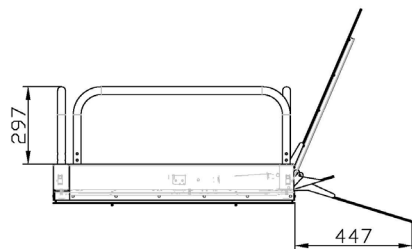
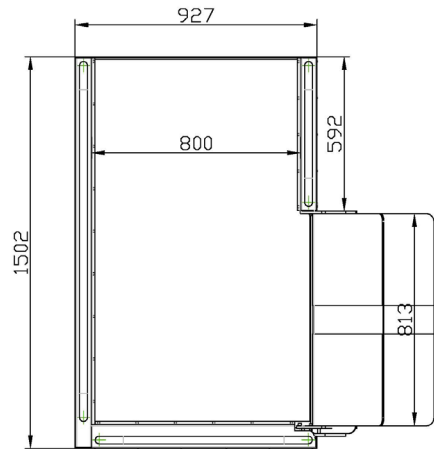
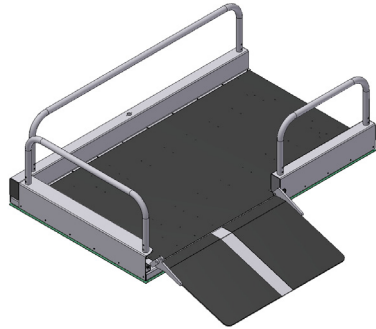

Side exit on upper landing (showing type 2)

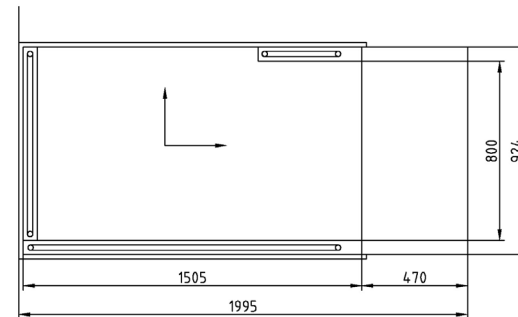
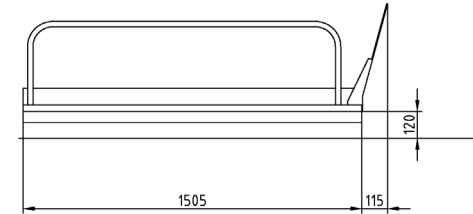
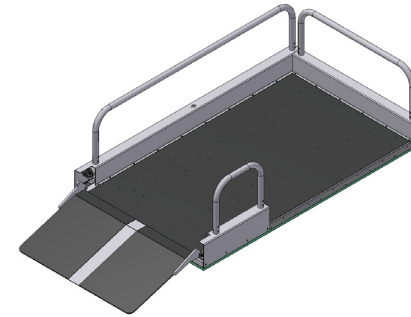

Door on upper landing pillars next to door (standard)

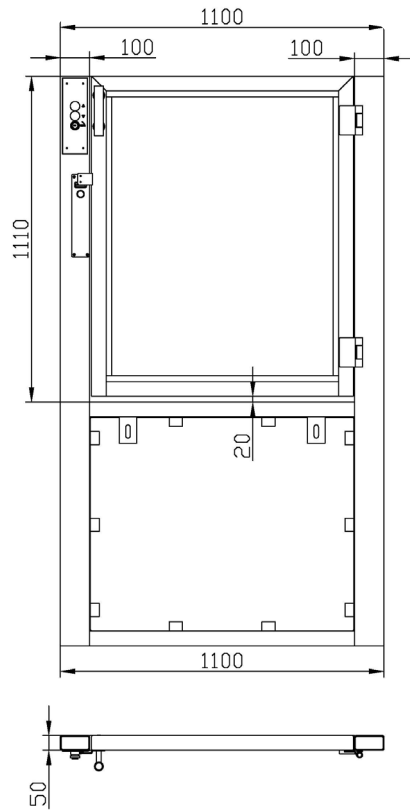
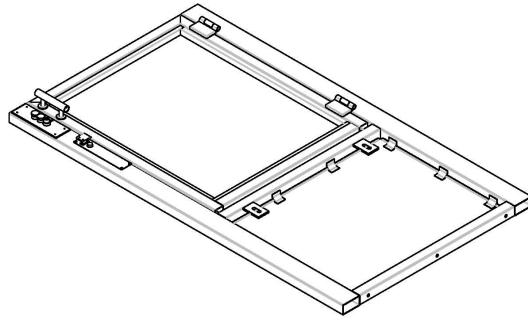

Door on upper landing pillars behind the door (not standard)

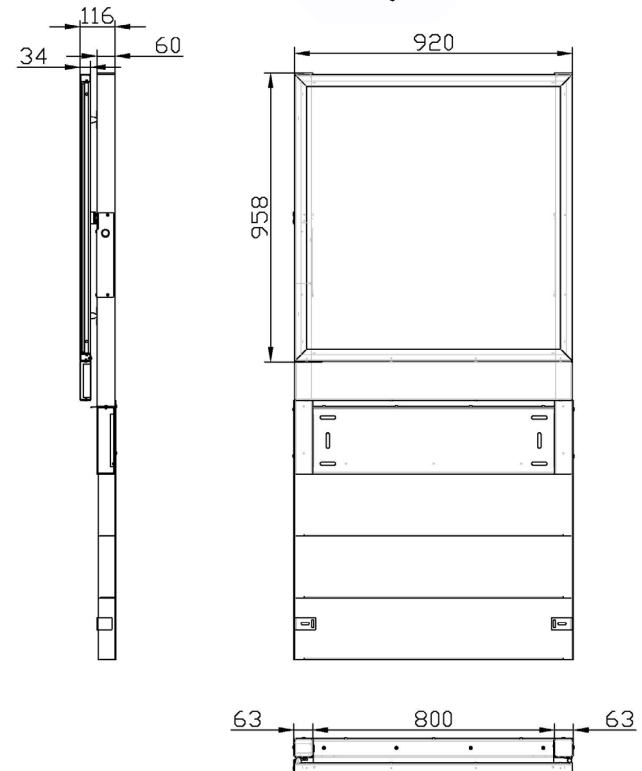
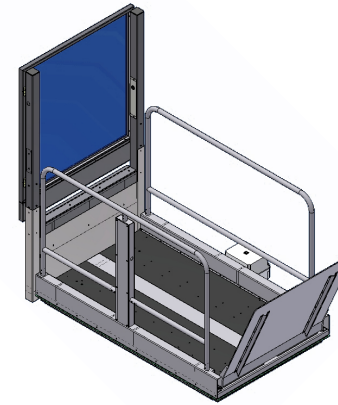

Safety bar on upper landing

